

ELECTRO-HYDRAULIC AND MECHANICAL POINT MACHINES

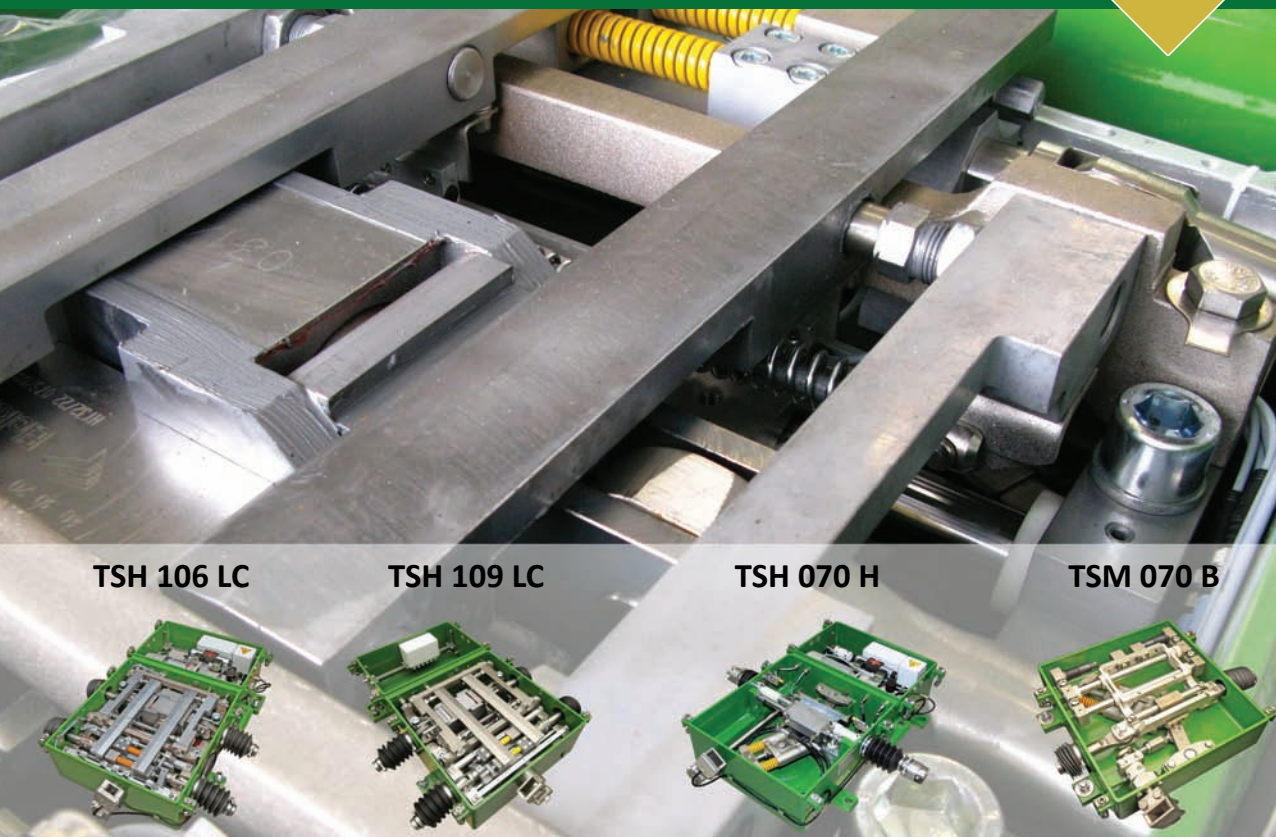

TSH 106 LC

TSH 109 LC

TSH 070 H

TSM 070 B



Elektroline



Introduction

Elektroline point machines are excellent choice for safe, reliable, and maintenance-free operation of tramway switch points.

The point machines are certified for up to SIL 3 safety level and are equipped with permanently checked mechanical locking mechanism.

Completely watertight casing with extra protection against water makes the point machine practically maintenance-free.

But enough promises. Let you try one of Elektroline point machines yourself and enjoy our 6 years warranty period.



	TSH 106 LC	TSH 070 H	TSH 109 LC	TSM 070 B
electro-hydraulic operation	●	●		
manual operation	●	●	●	●
watertight casing	●	●	●	●
watertight separation of electrical part (extra water protection)	●	●	●	
equipped with checking rods	●		●	
equipped with locking mechanism	●		●	
equipped with position sensors (6 independent sensors)	●		●	
equipped with position sensors (2 independent sensors)		●		○
humidity sensors	○	○	○	○
trailable	●	●	●	●
SIL 3 (AK 6) compliant for split points	●		●	
recommended for merge points				●
recommended for tram depots		●		●
suitable for self-reversing switches				●
height of the box (external)	200 mm	199 mm	200 mm	150 mm
length of the box (external)	830 mm	830 mm	830 mm	501 mm
width of the box (external)	596 mm	590 mm	596 mm	590 mm
operating voltage of hydraulic system	600-750 V DC, 230 V AC, 380 V AC, 110 V AC (60 Hz), etc...		mechanical only	

● included in basic option ○ possible option



Characteristic of point machines

Electro-hydraulic operation

These point machines enable automatic movement based on electro-hydraulic system integrated within the point machine. Compared to the older principle of elec-

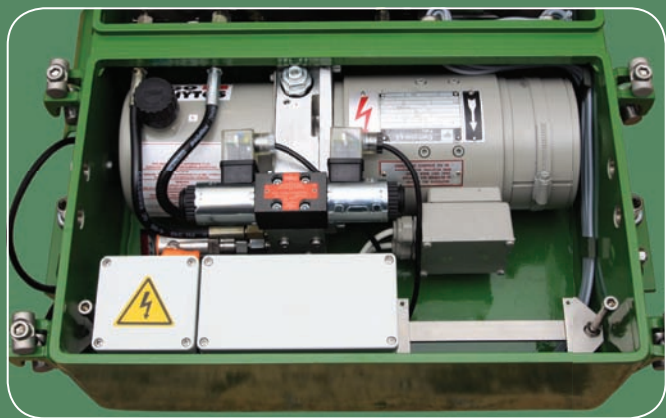

Electro-hydraulic system of point machine

tro-magnetic system, the electro-hydraulic principle has many advantages:

- Movement of the switch tongues is slower and much smoother; noise level produced by switch is markedly reduced as well as possible risk of injuries in the switch.
- Thanks to the slow and smooth movement, lifetime of the point machine and of the switch blades is much longer. Therefore we are able to provide you longer guarantee period for our point machines.

Maximum current necessary for moving the switch is

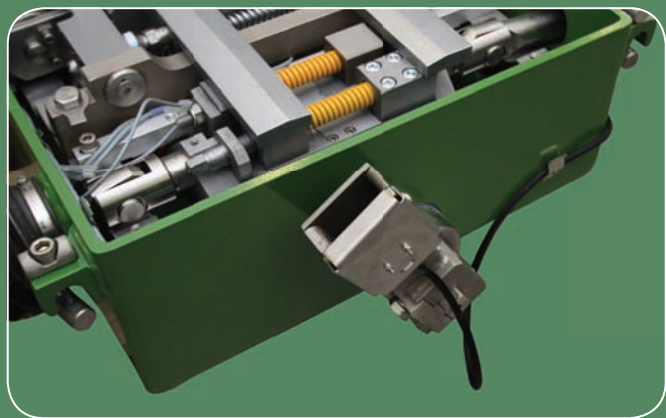

Socket for manual operation

much lower with the electro-hydraulic system and it therefore saves money on necessary power supply systems.

Manual operation

All Elektroline point machines are equipped with a socket for manual operation and can be therefore operated by hands when using manual operation bar.

We provide various types of customized sockets for manual operation.

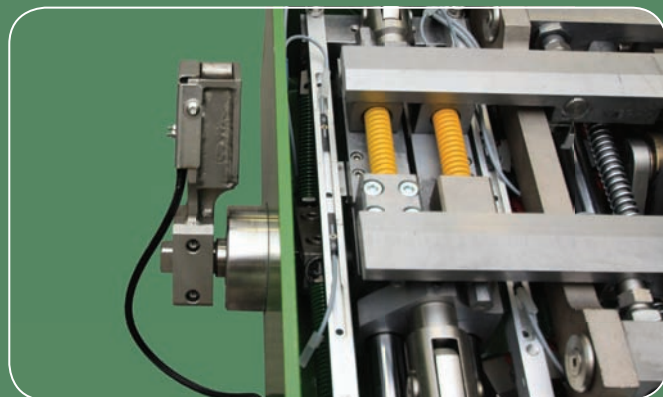

Socket for manual operation

Watertight casing

Although the point machine mechanisms have been developed in a way that the point machines can work with water in the inner mechanical parts, it is obvious that longer lifetime of the point machines is achieved due to the fact that the Elektroline point machines are installed in watertight casing.

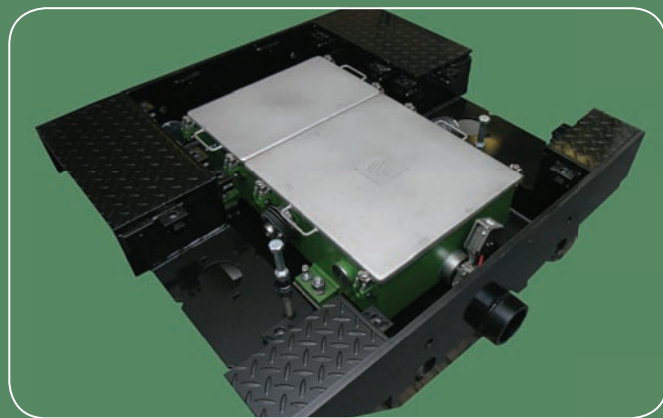

Watertight casing of Elektroline point machines

Electro-hydraulic operation



Manual operation

Watertight casing provides protection against:

- water (risk of corrosion, risk of lubrication failure)
- dust and mud (risk of jamming or extreme wearing of the mechanism)
- stones and other strange objects (risk of jamming the mechanism)

Especially at locations where road traffic can go over the point machine, it is very important to protect its mechanism by a watertight casing as the road traffic could carry a lot of impurities into it.

Each produced point machine is tested on water tightness during factory test after production.

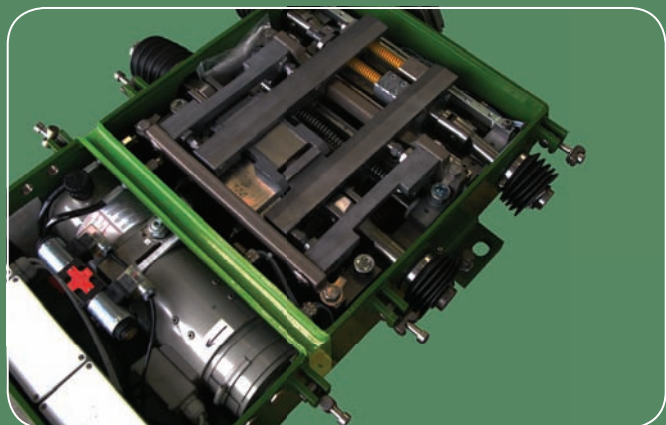

Watertight separation of electrical part

Watertight separation of electrical part (extra water protection)

As an extra protection against water, some point machines are equipped with a watertight partition that separates mechanical part of the point machine from the electrical and electro-hydraulic system in the point machine.

Even if the water leaked in the mechanical part of the point machine (it could happen for example by damaging a rubber sleeve covering entrance of a rod into the point machine), it will never get into the electrical part and the point machine can continue working even with water inside.

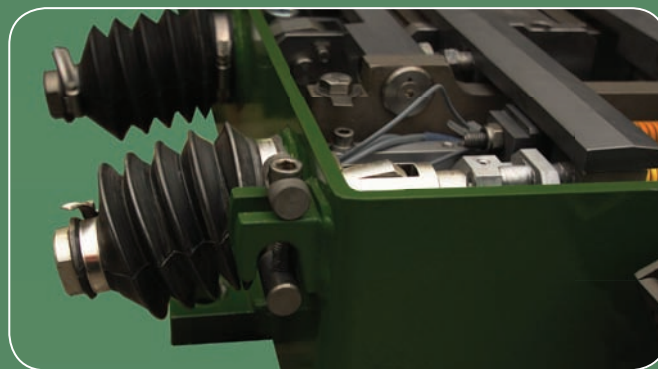

Checking rods

Equipped with checking rods

Checking rods increase safety of the point machine. They have two basic functions:

- Checking rods are equipped with independent position sensors and therefore give safe and reliable information about true position of the blades. Although checking of point position on the setting rod is also possible, checking of point position on the checking rods is much more safe and reliable.
- If the point machine is equipped with a locking mechanism, also the checking rods are being locked by this locking mechanism and the safety of the locking is therefore increased as the blade is being held in the correct position by two independent rods: by a setting rod and by a checking rod.

Equipped with locking mechanism

Locking mechanism is very important for switch points

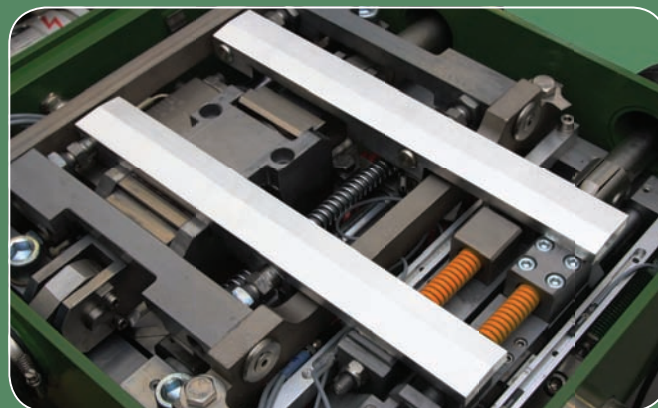

Locking mechanism inside a point machine



where trams travel in the facing direction carrying passengers. It is therefore recommended for majority of electrically operated switches on the main line and also for some mechanical switches on the main line.

Locking mechanism ensures that the adjacent blade will remain in its final position every time even (and especially) at the moment when a tram is travelling through the switch.

Equipped with position sensors (6 independent sensors)

Position sensors give safe and reliable information about actual position of the blades of the switch point and about status of locking of the point machine mechanism. Presence of position sensors is necessary to safely detect position of the switch and to display this information to the tram driver on a signal lamp.



Position sensors

In the full configuration (6 independent sensors), the point machine gives three independent information for each direction (left/right) about the proper position of the blades and the locking mechanism being active. Information from the position sensors can be processed independently (when using Elektroline control system) and can be analyzed independently by using special Elektroline switch point management software (ProSys software).

For each direction (left/right), point machine therefore gives independent information about:

- proper position of the left blade
- proper position of the right blade
- active function of the locking mechanism

Equipped with position sensors (2 independent sensors)

For point machines not equipped with any locking mechanism, 2 independent position sensors are installed to detect position of the switch, one sensor for each direction (left/right). The sensors detect position of the switch directly on the setting rod.

For each direction (left/right), point machine therefore gives information about:

- proper position of the blades (both left and right blade)

Equipped with humidity sensors

As additional equipment, the point machines can be equipped with two independent humidity sensors, one in each internal part of the point machine. The sensors send information to the control system in case water gets inside the point machine.

If combined with Elektroline switch point control system, alert SMS message can be immediately sent to predefined list of telephone numbers in case water gets inside the point machine including information about



Trailing mechanism is integrated within the lock body



number of switch point, time of the alert, etc.

Trailable

By *trailing*, we mean a situation when a tram goes through the switch in the trailing direction (along the blades) from the side where the switch is not set and therefore moves the switch mechanism by force of its own wheels.

Point machines not equipped with any locking mechanism can be trailed without any limits and can be therefore installed at merge points without any additional control system that would prevent their forced trailing.

Even the point machines equipped with a locking mechanism can be trailed without causing any damage to the mechanism as they are equipped with a special trailing mechanism. After being trailed through, the point machine can immediately continue in operation without necessity to replace any parts.

However trailing these point machines is not recommended to be done regularly and it should be prevented by appropriate control system, the point machines have been designed in a way that even regular and long time trailing does not cause any damage to the system.

Operating voltage of the hydraulic system

Point machines can be adapted for various types of power supply according to customer requirements. Elektroline point machine can work with 600-750 V DC

power supply which means that the power supply can be taken directly from the overhead contact line and no additional power supply is necessary.

As Elektroline switch point control system can also be supplied from the overhead contact line, Elektroline solution is perfect for remote locations where no 230V AC power supply is available.

If required, we can also adapt the point machines and control systems to be powered by 230V AC, 3x380V AC, 110V AC, or other, the only major modification is in using different type of electrical engine.

SIL 3 (AK 6) compliant for split points

Our point machines have been certified by an independent German certification authority and they can be used up to SIL 3 (AK 6) level of security which is the highest level of security used for tramway system operating in on-sight mode.

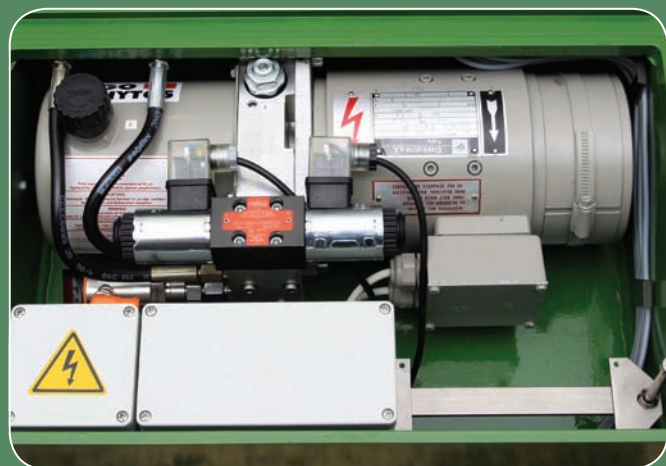

Elektroline compact 600-750 V DC electromotor



TSH 106 LC (SIL 3)

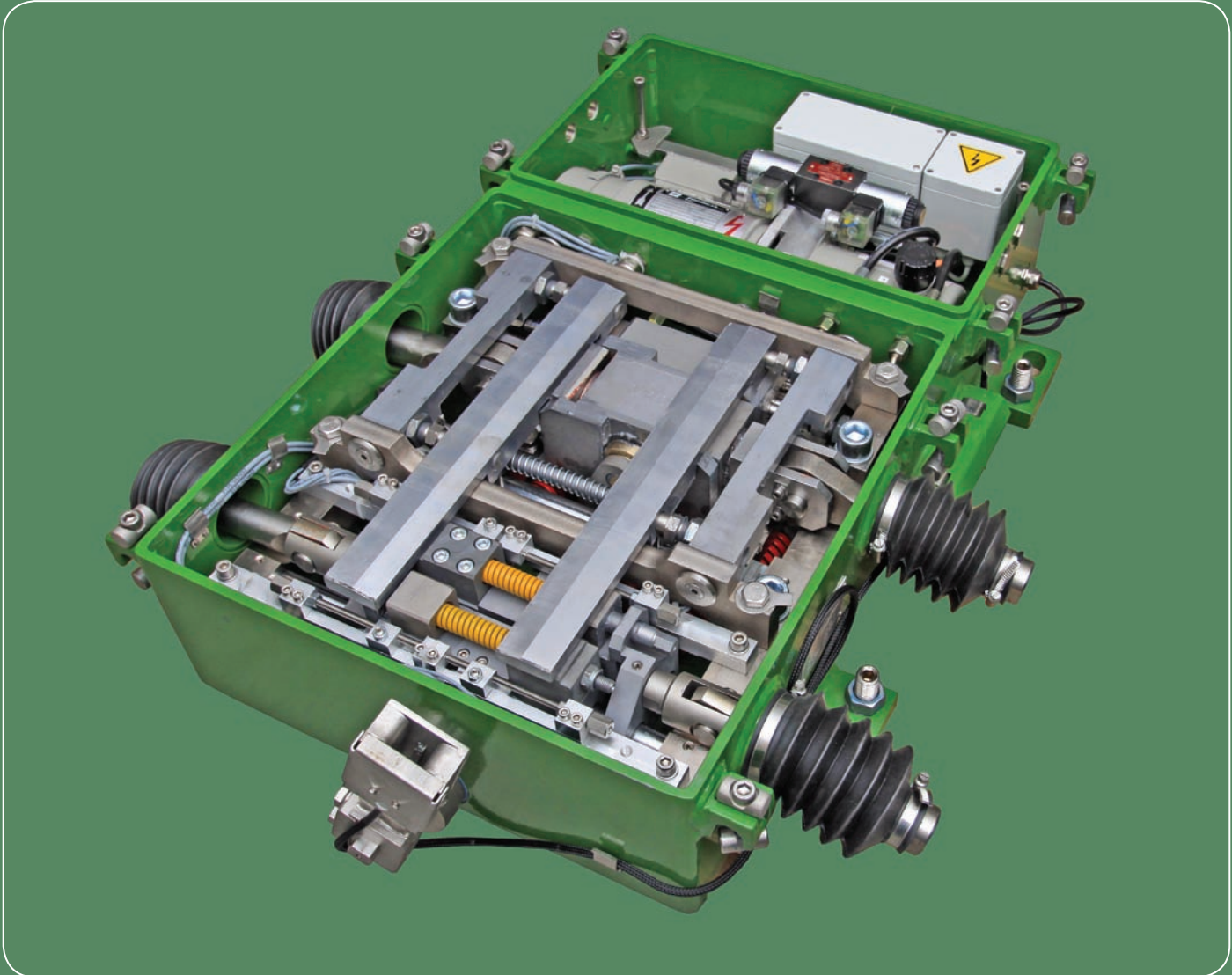

TSH 106 LC is the most sophisticated Elektroline point machine. It uses electro-hydraulic system for motorized movement of switch tongues and it has been certified for SIL 3 (AK 6) safety integrity level by an independent German certification authority. It can be used for split points and for locations where tram travel in the facing direction carrying passengers.

The TSH 106 LC point machines are usually used for switch points where tram carrying passengers go in the facing direction and where automatic change of direction is required. It can be installed at various locations

from very frequently used switch points in the city centers to higher speed switch points at suburbs.

By implementing a special trailing mechanism, regular trailing of the point machine is possible despite the fact that the point machine is equipped with a fixed locking mechanism and is certified for SIL3 safety integrity level. This trailing mechanism enables safe movement of the point machine in case of forced trailing and enables that the system can immediately continue in operation without any safety risk or damage to the mechanisms after it has been trailed through.

Electro-hydraulic operation



Manual operation

The TSH 106 LC point machine offers best performance when installed together with Elektroline switch point control system TSC. Elektroline switch point control system TSC (also certified up to SIL3 safety integrity level) can monitor all information from the TSH point machine independently, store this information in a log file and provide remote real-time access to all data using special monitoring software Elektroline ProSys.

- **Watertight casing with separated electrical part:** The point machine works even if a rubber sleeve of a rod is broken and the mechanical part is full of water
- **Electro-hydraulic system combined with 600-750 V DC power supply:** Power supply for the point machine can be taken directly from the overhead contact line without need for any additional power supply



Highlights

- **SIL 3 certification:** Certified for the highest safety level used for tram track operation by an independent German certification agency
- **Trailable:** Special trailing mechanism in the point machine ensures that the point machine is not damaged during trailing when respecting high safety demands resulting from SIL 3 certification

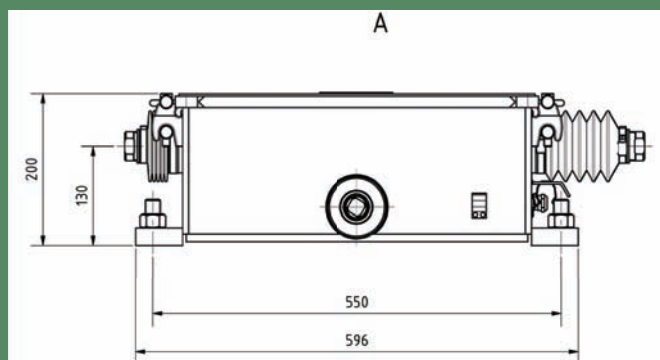
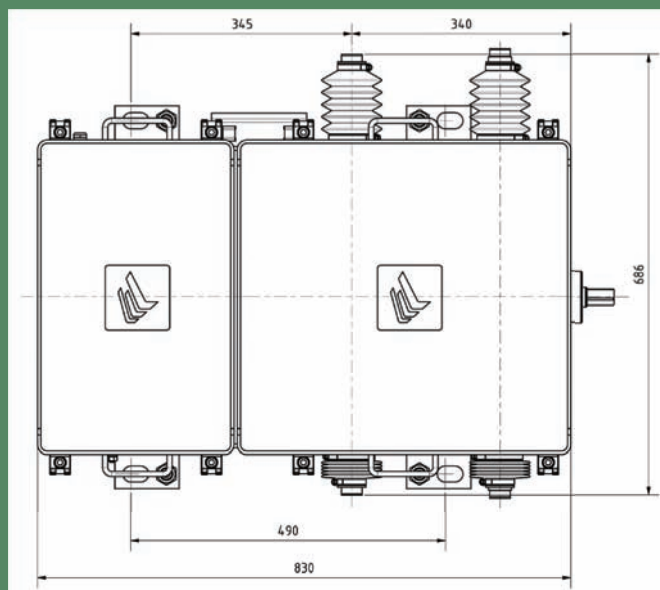
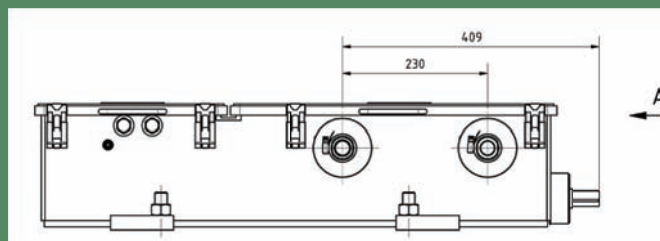
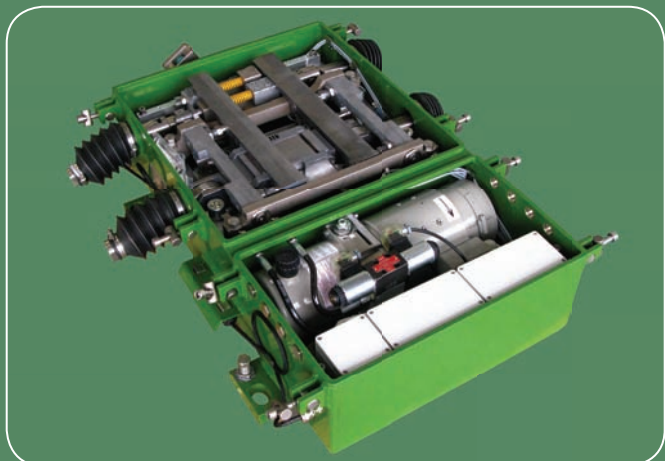



TSH 070 H

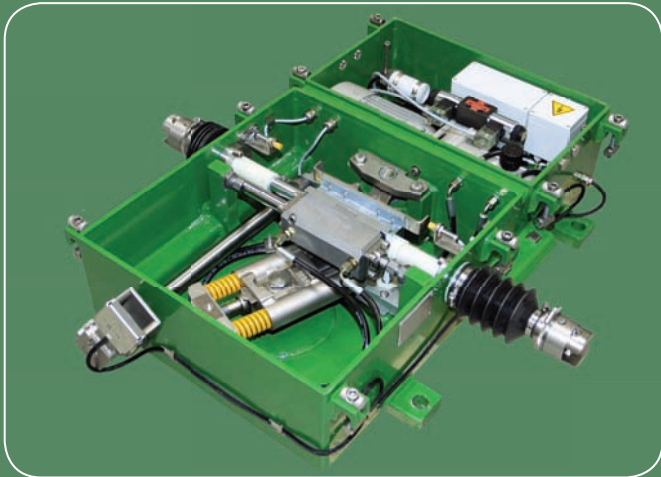

Point machine TSH 070 H

The TSH 070 H point machine is an electro-hydraulic point machine dedicated to be used in tram depots or at locations where regular trailing of the point machine is required and where trams do not carry any passengers. It has similar external dimensions as the TSH series point machines and can be therefore installed in the same ground box, its outer dimensions drawings are however different as this point machine does not have any checking rods.

The TSH 070 H point machine:

- Uses the electro-hydraulic power equipment same as used in the TSH series point machines

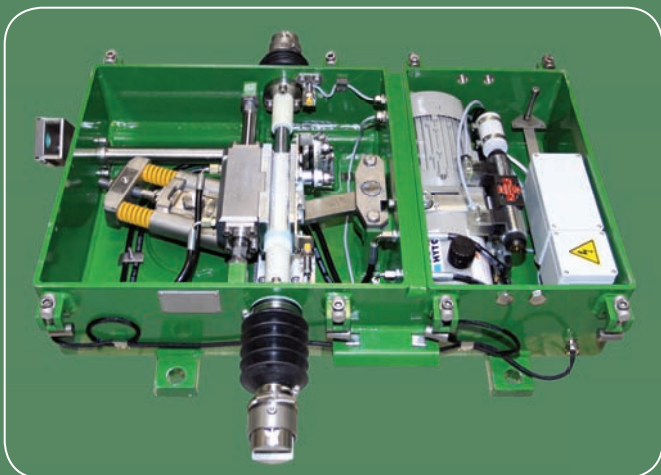

TSH 070 H does not have any checking rods

- Is completely watertight (IP68 rating) - electrical and mechanical parts are separated by a watertight partition
- It does not have any locking mechanism as it has to enable regular trailing. The switch tongues are held in the final position by the **thrust springs**.
- Its position is checked by two independent position sensors measuring position of the setting rod (no checking rod is present).

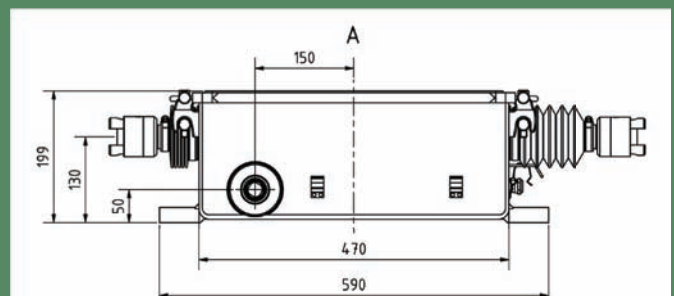
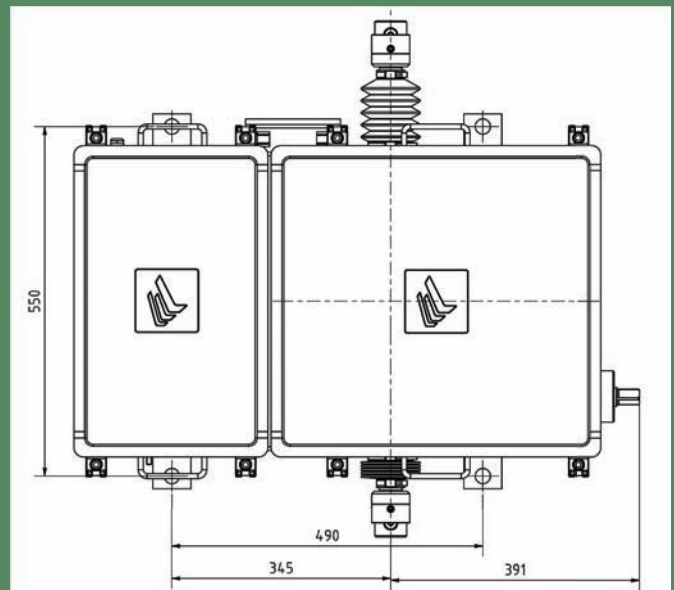
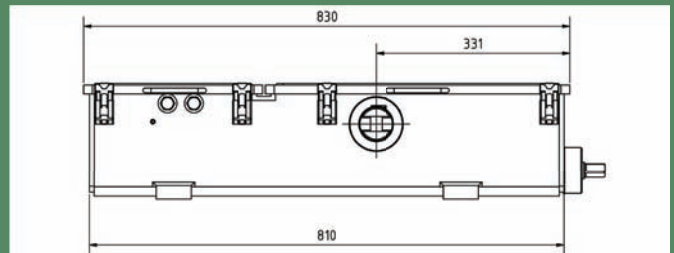



TSH 109 LC (SIL 3)

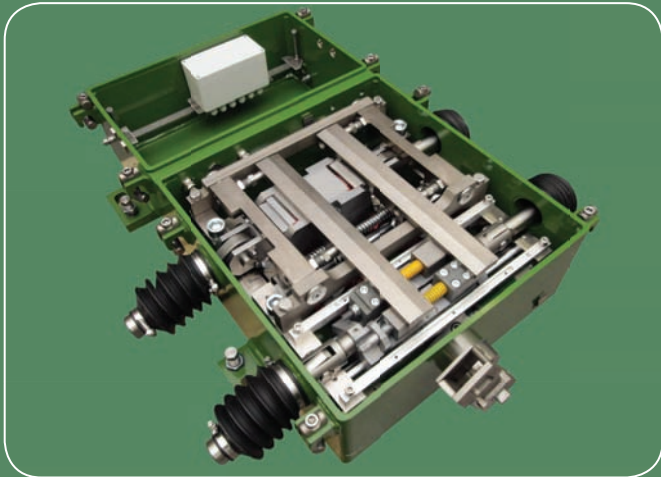

Point machine TSH 109 LC (SIL 3)

The TSH 109 LC is modification of the TSH 106 LC for locations where no automatic operation of the switch point is required but SIL 3 certification is required. It is recommended for switch points used by passenger-carrying trams in the facing directions at locations where change of direction occurs only rarely and most of the trams go in the same direction.

The point machine has the same parts as the TSH 106 LC point machine, only the electro-hydraulic system is missing in the point machine. It therefore offers the same safety level as the TSH 106 LC point machine but it is not possible to move it electrically.

As the point machine is equipped with 6 independent

position and locking sensors, it is possible to connect it to special Elektroline control system for mechanical point machines and to display its position and locking status on a point position indicator.

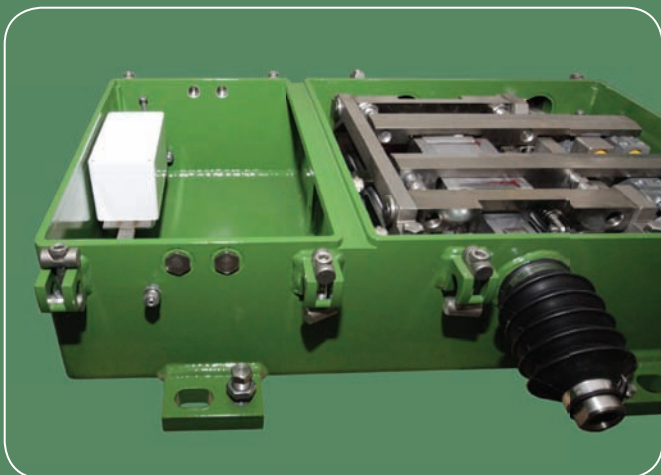
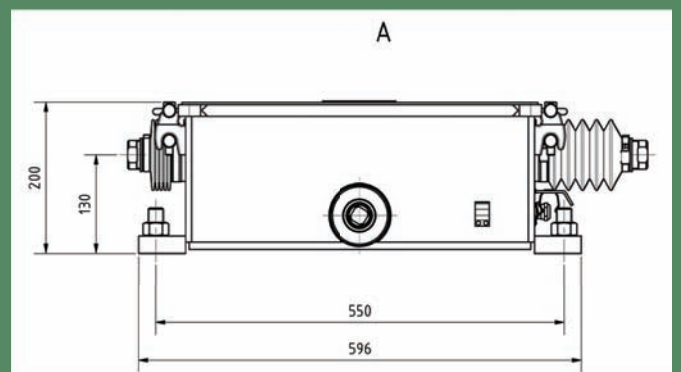
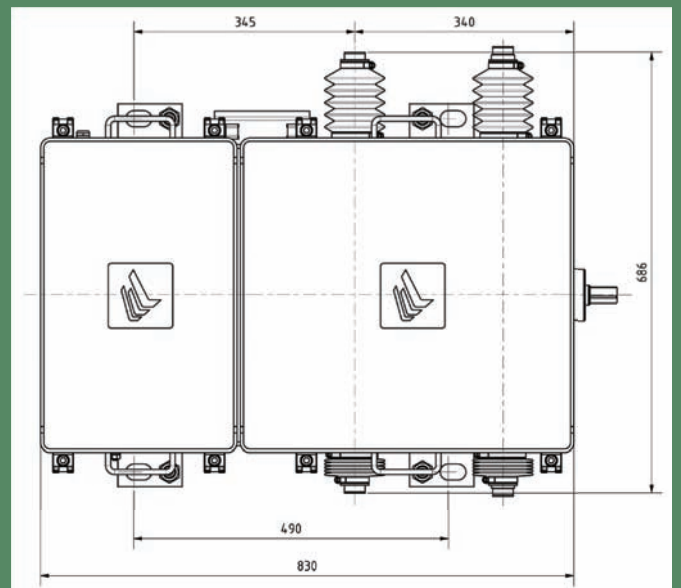
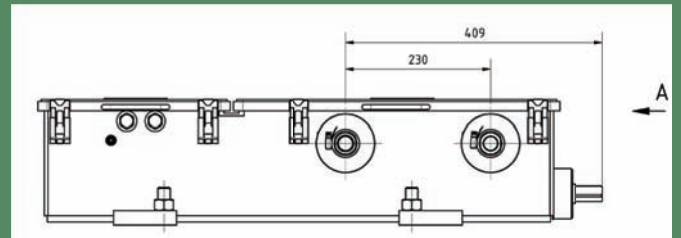

The electro-hydraulic part is missing in TSH 109 LC (SIL 3)



TSM 070 B

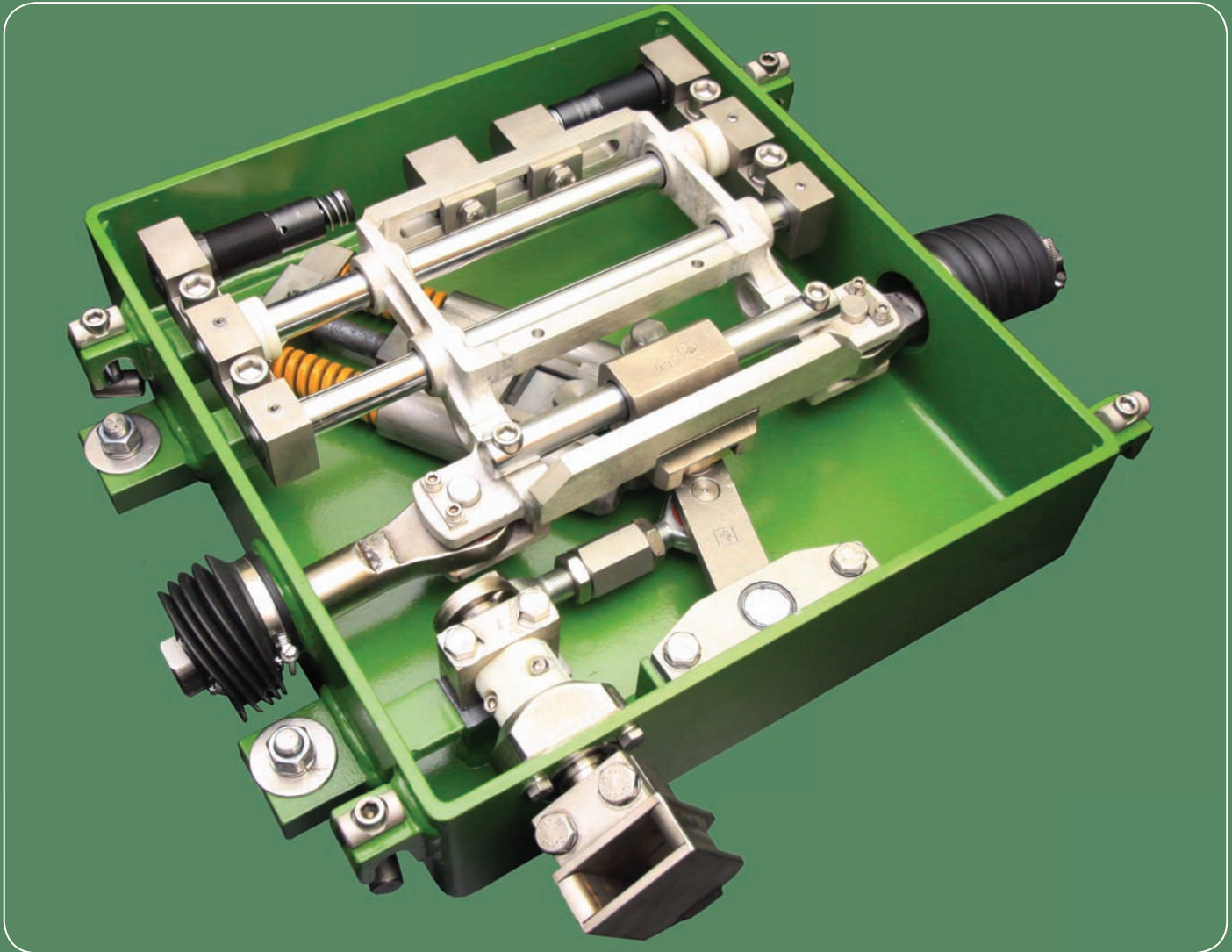

The TSM 070 B mechanical point machine is a state-of-art point machine for locations where no motorized operation of a switch point is required and where no passenger-carrying-trams travel in the facing direction.

Unlike most competitors' products, the TSM 070 B is **completely watertight** and therefore requires less maintenance and offers longer lifetime. Especially at locations with road traffic over the switch point, at locations with frequent rain-fall or snow-fall, at locations close to the sea or at any other locations where humidity or impurities could get into the point machine mechanism is the water tightness of the complete point machine a big advantage.

The TSM 070 B point machine has two possible modes of operation: **hand-operated mode** and **self-reversal mode**.

In the **hand-operated mode**, the point machine can be used at merge points (where all trams go in the trailing direction) or at switch points where no passenger-carrying trams go in the facing direction. When tram goes in the facing direction and needs to change the switch position, it can be done manually by using the hand-operation mechanism. In the trailing direction, the switch is being moved by the force created by tram wheels; the point machine helps to finalize the movement and holds the switch tongues in the final position.

Electro-hydraulic operation



Manual operation

In the **self-reversal** mode, the point machine is permanently set into one direction (left or right) so that all trams traveling in the facing direction go the same way. When the point machine is trailed, it returns back automatically into the preset position just after passage of a tram bogie. The hand-operation mechanism remains active even in the self-reversal mode and the direction can be therefore changed manually in case any tram needs to go in the facing direction the way where the switch is not preset.

The point machine can be very easily readjusted from the **hand-operated mode** into the **self-reversal mode** and vice versa by a simple rotation of a guide block inside the point machine system which can be done with in approx. 10 minutes directly on site without necessity to uninstall the point machine from the ground.

Installation height of the point machine (excluding any ground box) is only 136 mm. It can be therefore easily installed directly on sleepers without requiring any major civil works. Even when installed in a ground box, requirements for installation depth are not high and the point machine slim construction therefore saves a lot of money on civil works and track bed adjustments.

A pair of **dampers** is installed in each TSM 070 B point machine in order to damp vibrations from the point machine system. The dampers can be adjusted independently for each direction (left or right) in order to achieve best performance. Operation of the point machine is therefore very silent and smooth even during trailing in the self-reversal mode.

By using a special installation adaptor, the TSM 070 B point machine can be used as replacement for an electro-hydraulic point machine in case the electro-hydraulic point machine needs to be uninstalled.

When point position indicator is required to show switch position to tram drivers, the TSM 070 B point machine can be equipped with two independent **position sensors** monitoring position of the point machine setting rod.

Highlights

- **Watertight casing:** Unlike most competitors' prod-

ucts, the TSM 070 B is completely watertight and therefore requires less maintenance and offers longer lifetime

- **Perfectly silent:** Due to careful design of the dampening mechanism is the TSM 070 B point machine one of the most silent and smooth mechanical point machine on the market
- **Universal use:** Two operation modes (hand-operated mode and self-reversal mode) can be switched easily and the point machine can be therefore easily adapted to changing traffic rules within your tram network
- **Low installation height:** With its installation height of only 136 mm, the TSM 070 B saves a lot of money on civil works and track bed adjustments

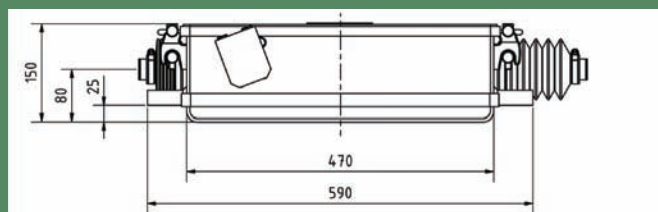
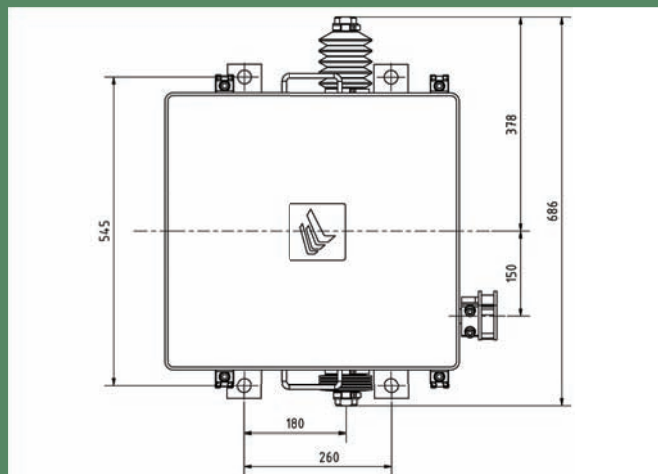
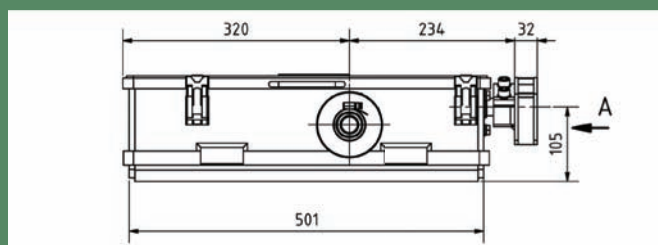



Elektroline
point machines

CHOSEN REFERENCES



Blackpool, United Kingdom, 2009-11

- point machines (electro-hydraulic and mechanical)
- switch point control system (SIL 3)
- VETRA tram-to-wayside communication system
- depot signaling system (Vetra communication)



Gaziantep, Turkey, 2010-11



- point machines (electro-hydraulic and mechanical)
- semi-automatic depot control system
- VETRA tram-to-wayside communication system
- tram priority system



- point machines (electro-hydraulic and mechanical)
- switch point control systems
- PRIPAT tram-to-wayside communication system
- depot signaling system
- tram priority system



Szeged, Hungary, 2008-11



- point machines (electro-hydraulic and mechanical)
- terminal station automatic signaling system



Athens, Greece, 2007



Electro-hydraulic operation



Manual operation



Pilsen, Czech Republic, 1992-2011

- point machines (electro-hydraulic)
- switch point control system (SIL 3)
- VETRA tram-to-wayside communication system
- automatic switch point heating



The Hague, Netherlands, 2008



- point machines (electro-hydraulic and mechanical)
- switch point control system (SIL 3)



- point machines (electro-hydraulic and mechanical)



Brussels, Belgium, 2007-09

OTHER POINT MACHINES REFERENCES



Belgium (Ghent)



Czech Republic (Prague, Liberec, Olomouc)



Netherlands (Delft)



Poland (Poznań, Bydgoszcz, Łódź, Gdańsk)



Italy (Milan)

Elektroline Inc.
K Ládví 20
184 00 Prague 8
Czech Republic
phone: +420 284 021 111
fax: +420 284 021 119
e-mail: info@elektroline.cz
www.elektroline.cz

